

**FOUR
STROKE
MARINE
ENGINES**

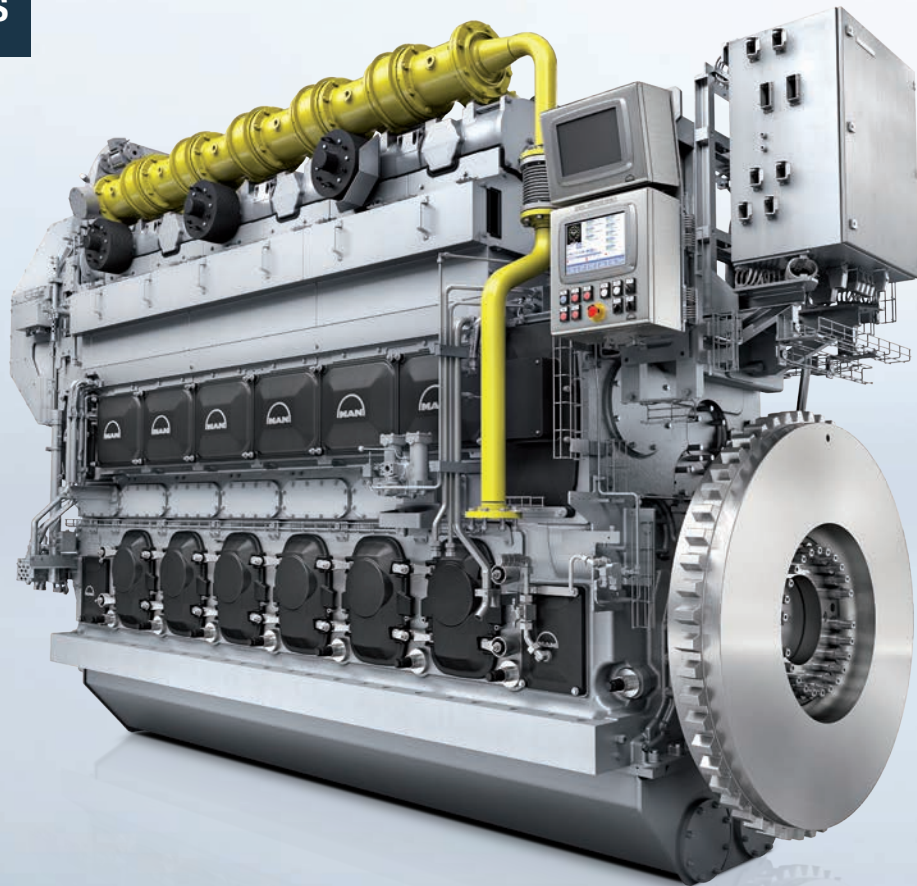

MAN L35/44DF

PROPULSION

The MAN 35/44DF embodies all the benefits of dual fuel flexibility. In gas mode, it complies fully with IMO Tier III standards. Based on the proven MAN 32/44CR, its reliable technology reduces daily maintenance and maximizes TBOs while ensuring safe operation in all fuel modes.

Benefits at a glance

- High efficiency
- High specific power output
- IMO Tier III-compliant in gas mode
- Full fuel flexibility
- High reliability and long maintenance intervals

Engineering the Future – since 1758.

MAN Diesel & Turbo



MAN L35/44DF

PROPULSION

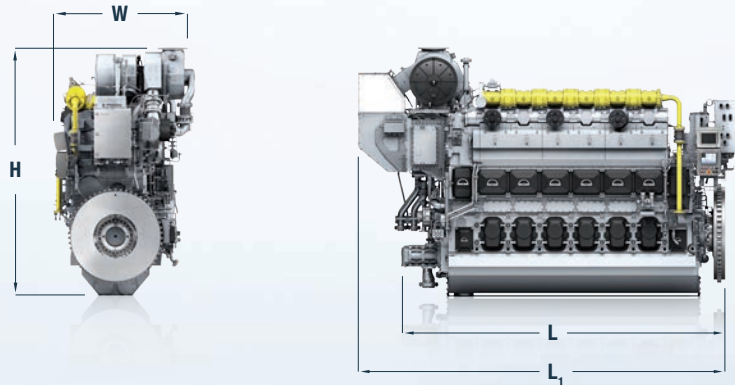

Dimensions

Cyl. No.	6	7	8	9	10	
L	6,485	7,015	7,545	8,075	8,605	mm
L ₁	5,265	5,877	6,407	6,937	7,556	mm
W	2,539	2,678	2,678	2,678	2,678	mm
H	4,163	4,369	4,369	4,369	4,369	mm
Dry mass ¹⁾	43.1	48.2	53.3	57.6	62.3	t

Output

Speed	750	720	rpm
mep	20.0	20.1	bar
MAN 6L35/44DF	3,180	3,060	kW
MAN 7L35/44DF	3,710	3,570	kW
MAN 8L35/44DF	4,240	4,080	kW
MAN 9L35/44DF	4,770	4,590	kW
MAN 10L35/44DF	5,300	5,100	kW

LHV of fuel gas $\geq 28,000$ kJ/Nm³ (Nm³ corresponds to one cubic meter of gas at 0 °C and 1.013 bar)
 Minimum centreline distance for twin engine installation: 2,500 mm | V-engine type under preparation
¹⁾ Including built-on lube oil automatic filter, fuel oil filter and electronic equipment
 Speed 720 rpm for generator drive only
 Last updated August 2016

General

- Engine cycle: Four-Stroke
- No. of cylinders: 6, 7, 8, 9, 10
- Bore: 350 mm – Stroke: 440 mm
- Swept volume per cyl: 42.3 dm³

Fuel consumption at 85 % MCR

- SFOC: 175.5 g/kWh (liquid fuel operation)
- SFGC: 7515 kJ/kWh (gas operation)

Cylinder output (MCR)

- At 750 rpm: 530 kW
- At 720 rpm: 510 kW
- Power-to-weight ratio: 11.8 – 14.1 kg/kW

Compliance with emission regulations

- IMO Tier II
- IMO Tier III (with MAN SCR)

Main features

- Turbocharging system**
High efficiency constant pressure MAN TCR series exhaust turbocharging system

MCR = Maximum Continuous Rating | SCR = Selective Catalytic Reduction
 SFOC = Specific Fuel Oil Consumption | SFGC = Specific Fuel Gas Consumption

- Engine automation and control**
MAN in-house developed engine attached Safety and Control System **SaCoS_{one}**

- Fuel system**
Common Rail pilot fuel injection system
Advanced electronic Common Rail main injection system

- Gas system**
Cylinder individual low pressure gas admission system, 5 bar(g) at inlet of gas valve unit

- Cooling system**
2-string high and low temperature cooling water systems

- Starting system**
Pressurized air starter (turbine type)

- Engine mounting**
Resilient or rigid mounting

Optional equipment

- Additional Power Take-Off at engine free end available

MAN Diesel & Turbo, 86224 Augsburg, Germany
 Phone +49 821 322 0, Fax +49 821 322 3382
 info@mandieselturbo.com, www.marine.man.eu